

APPROVED
 TRAFFIC ENGINEER/COIL ENGINEER LICENSE NO. 5423
 TO ACCOMPANY PLANS DATED _____

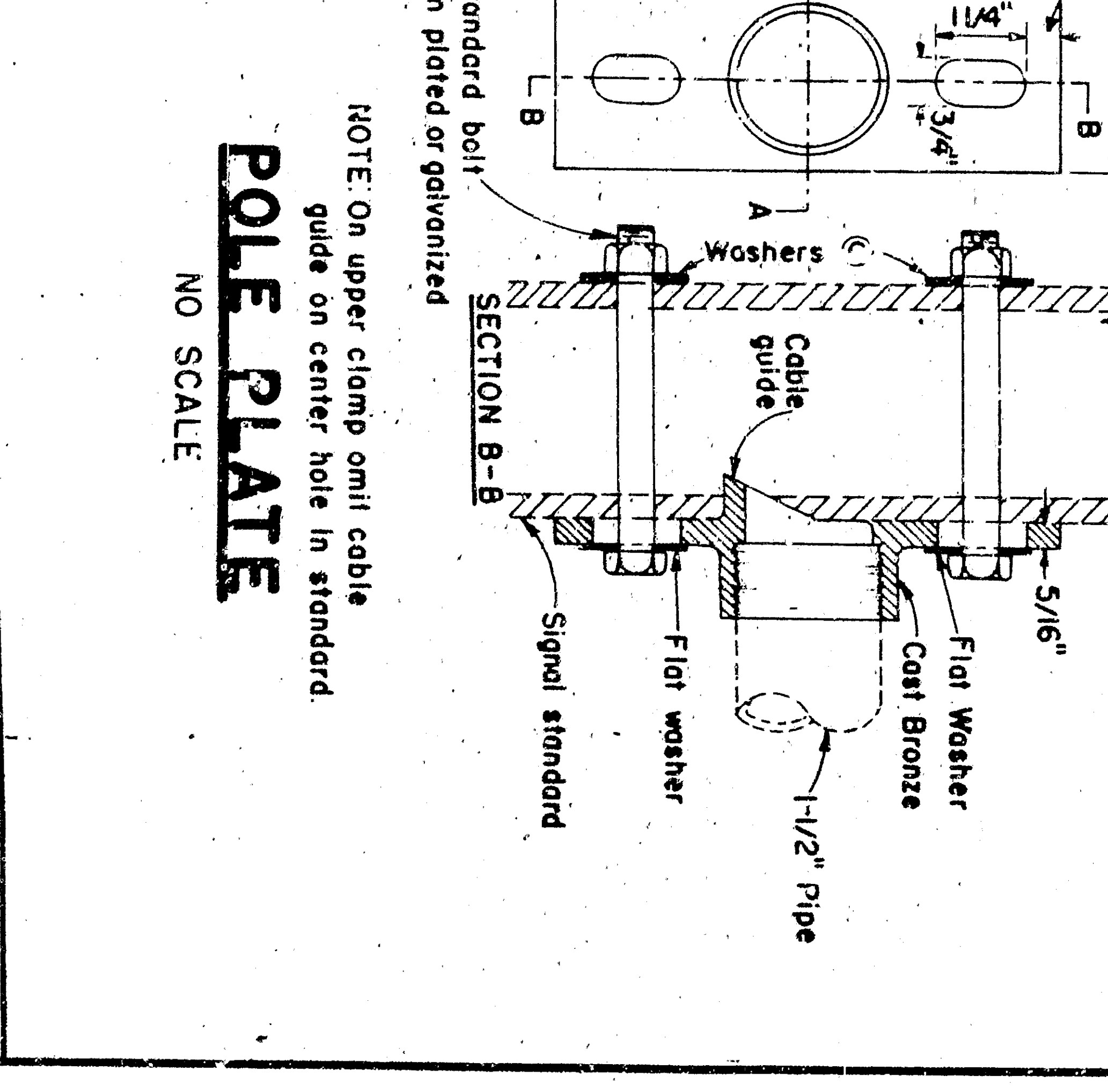

APPROVED
 TRAFFIC ENGINEER/COIL ENGINEER LICENSE NO. 5423
 TO ACCOMPANY PLANS DATED _____

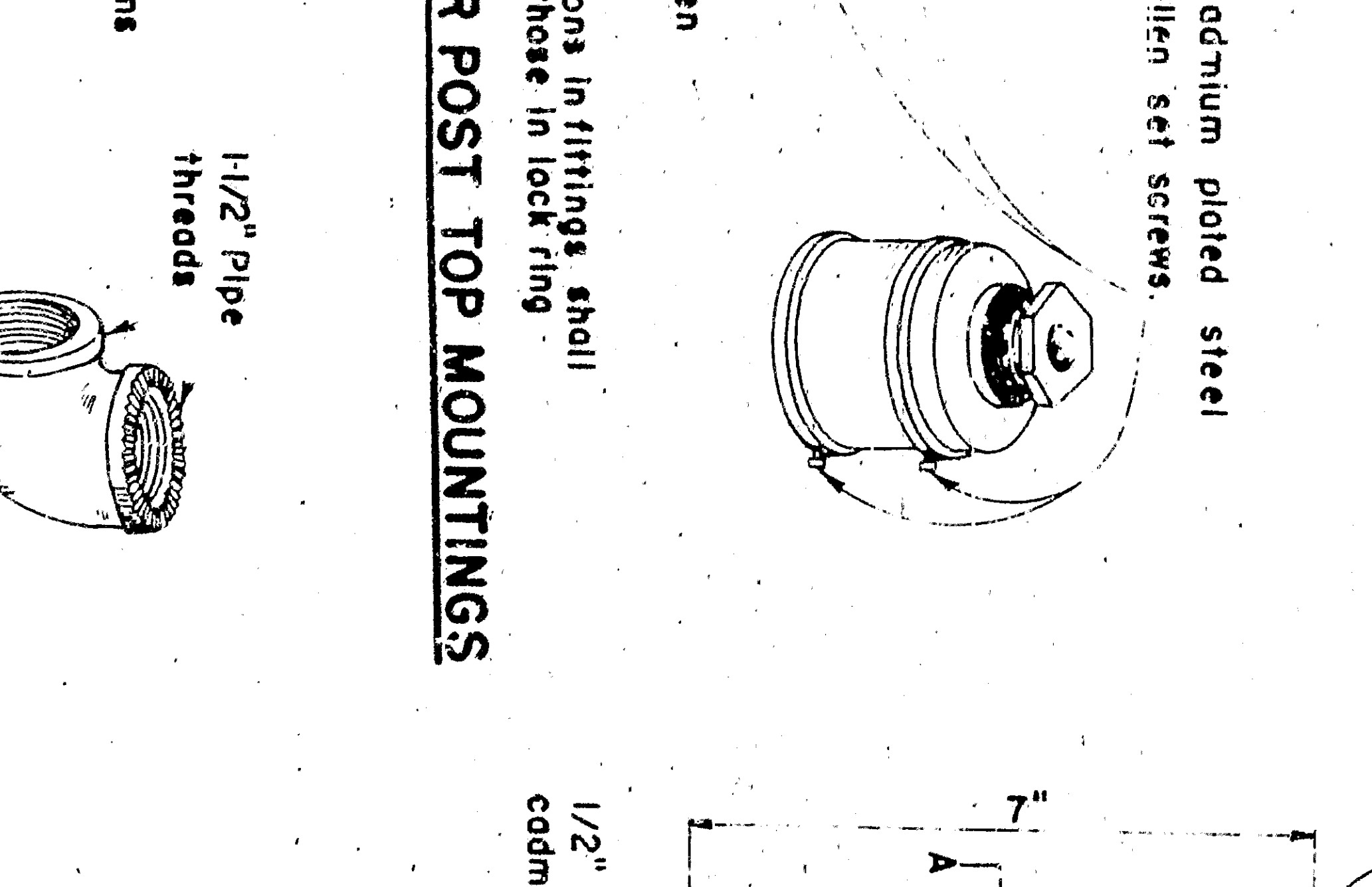
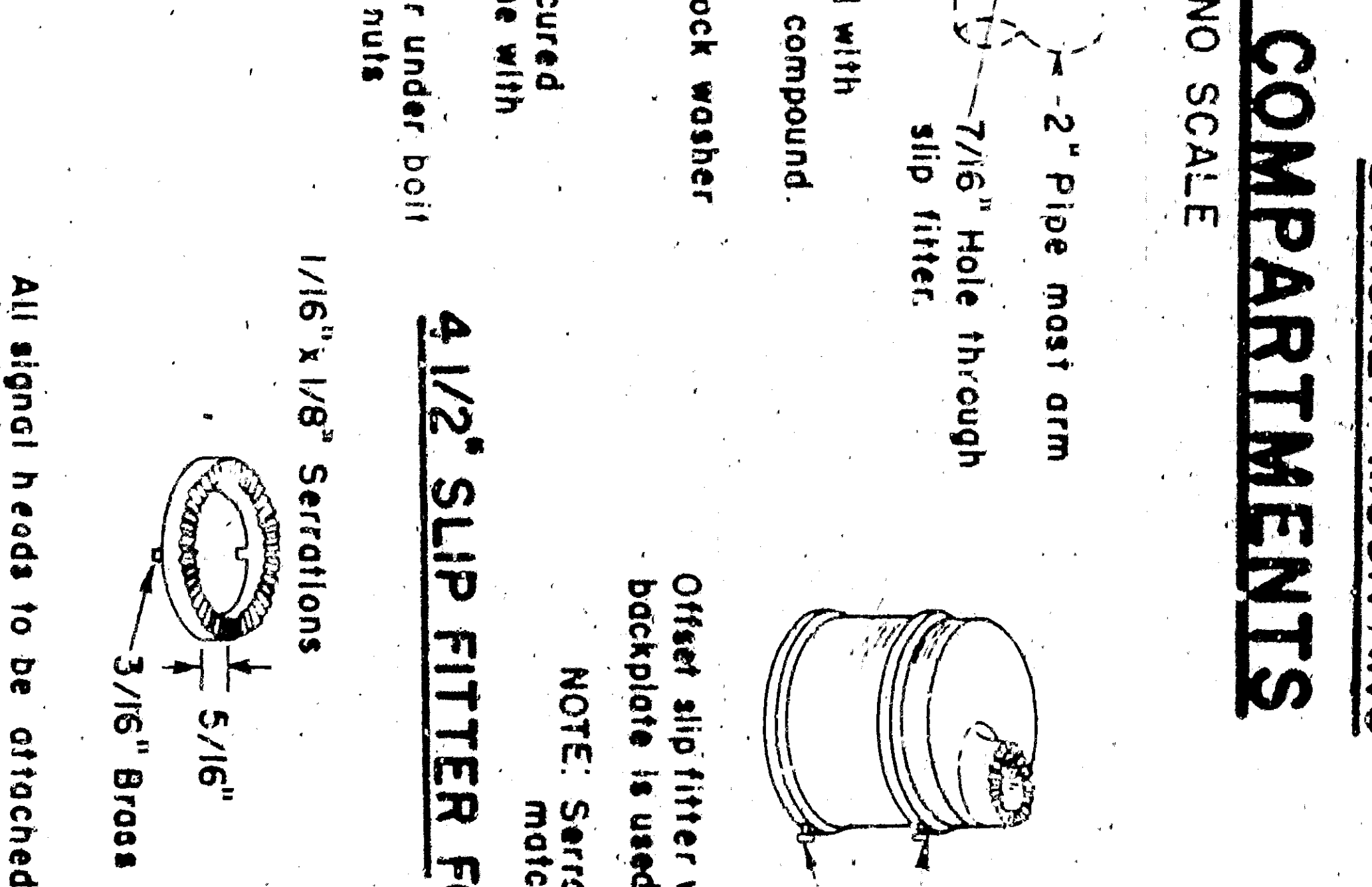
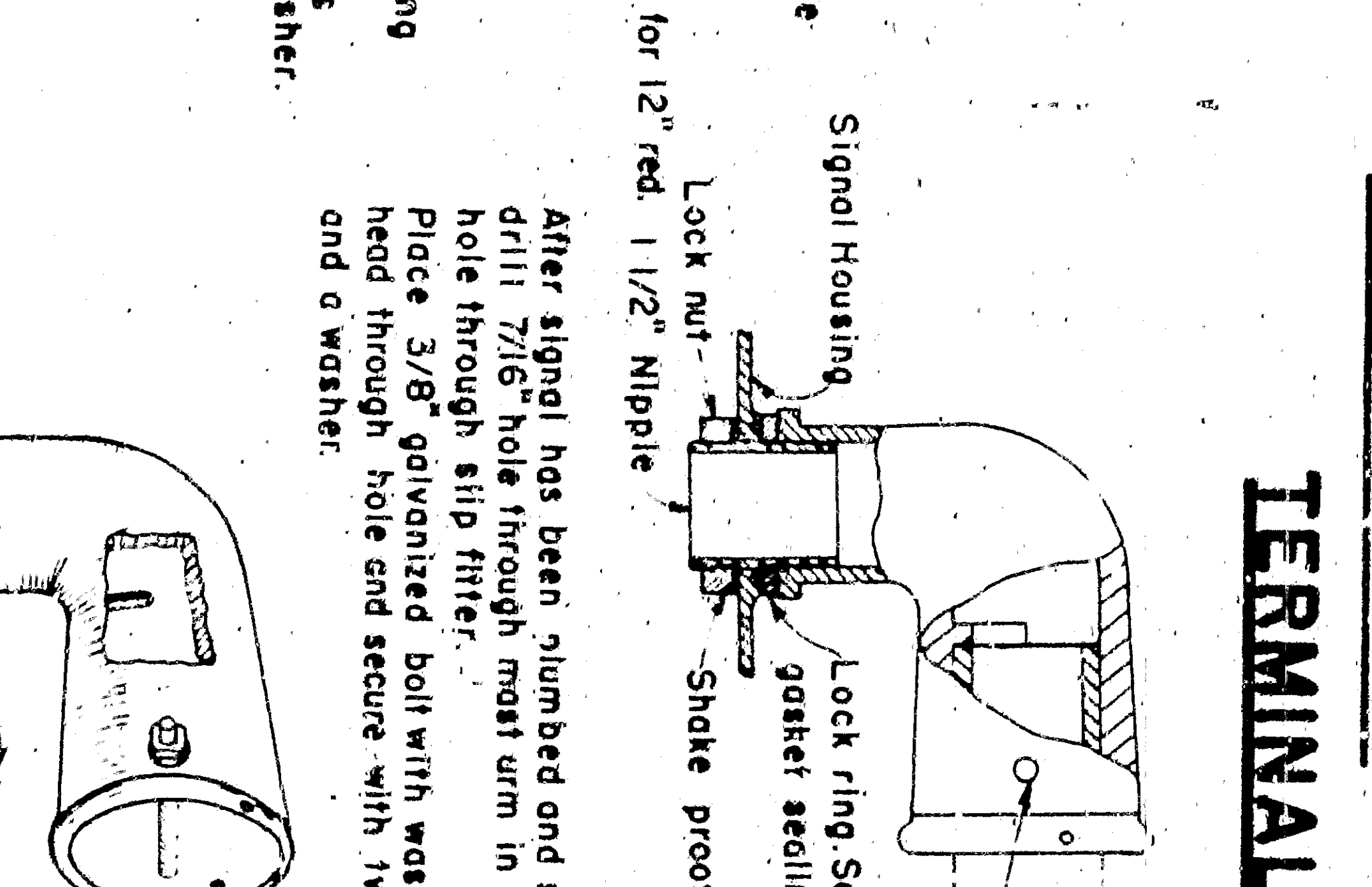
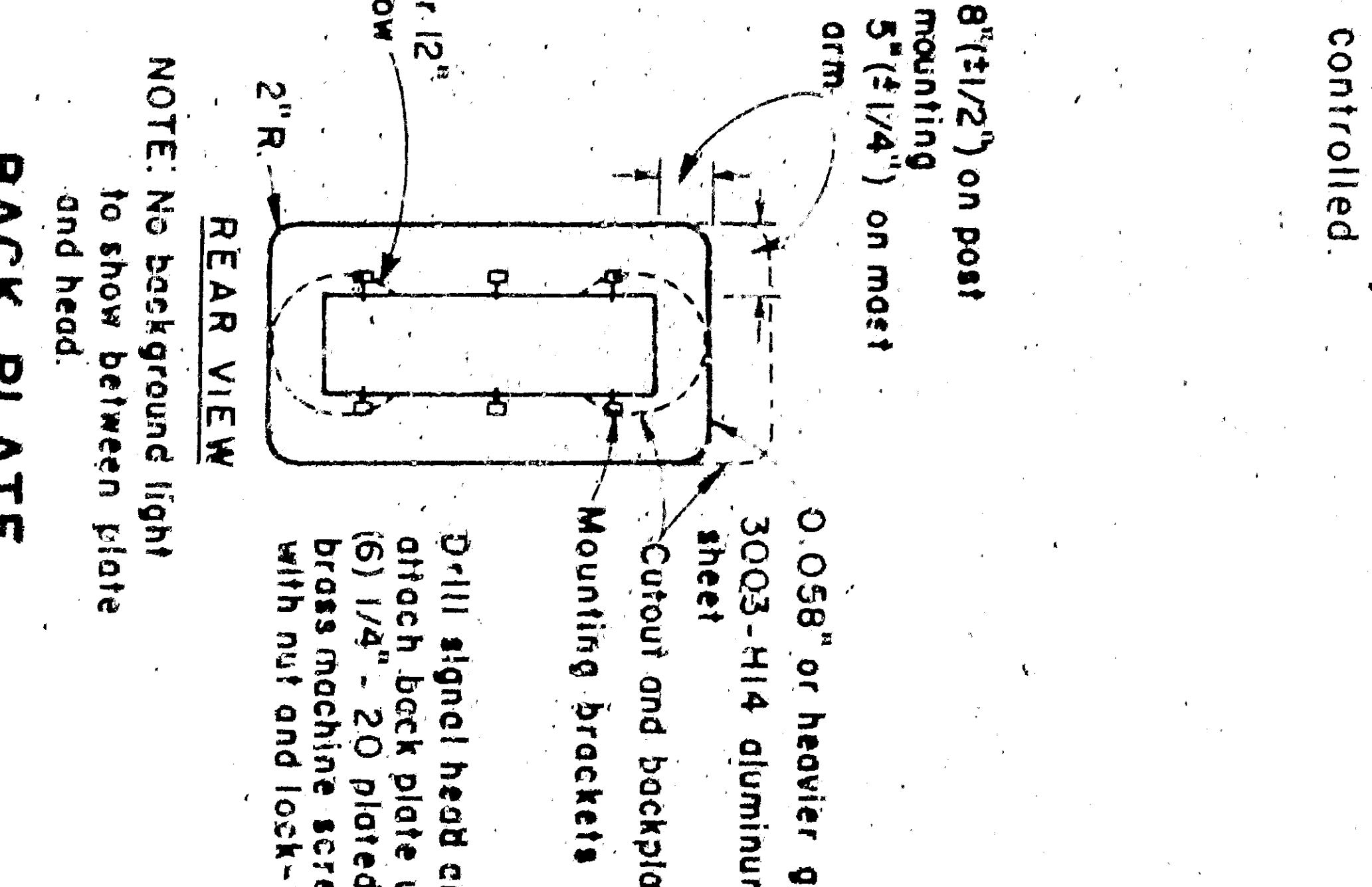
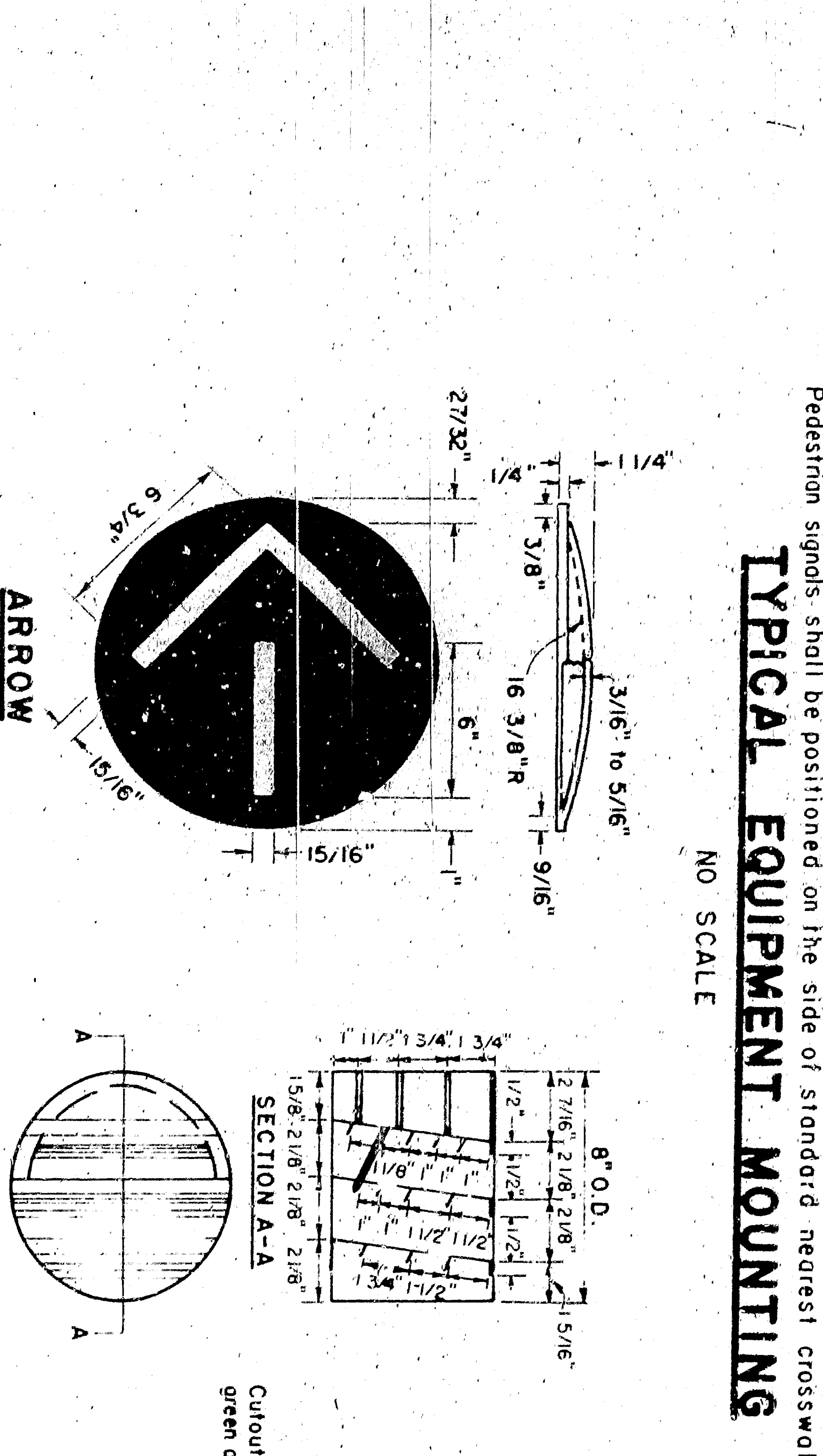
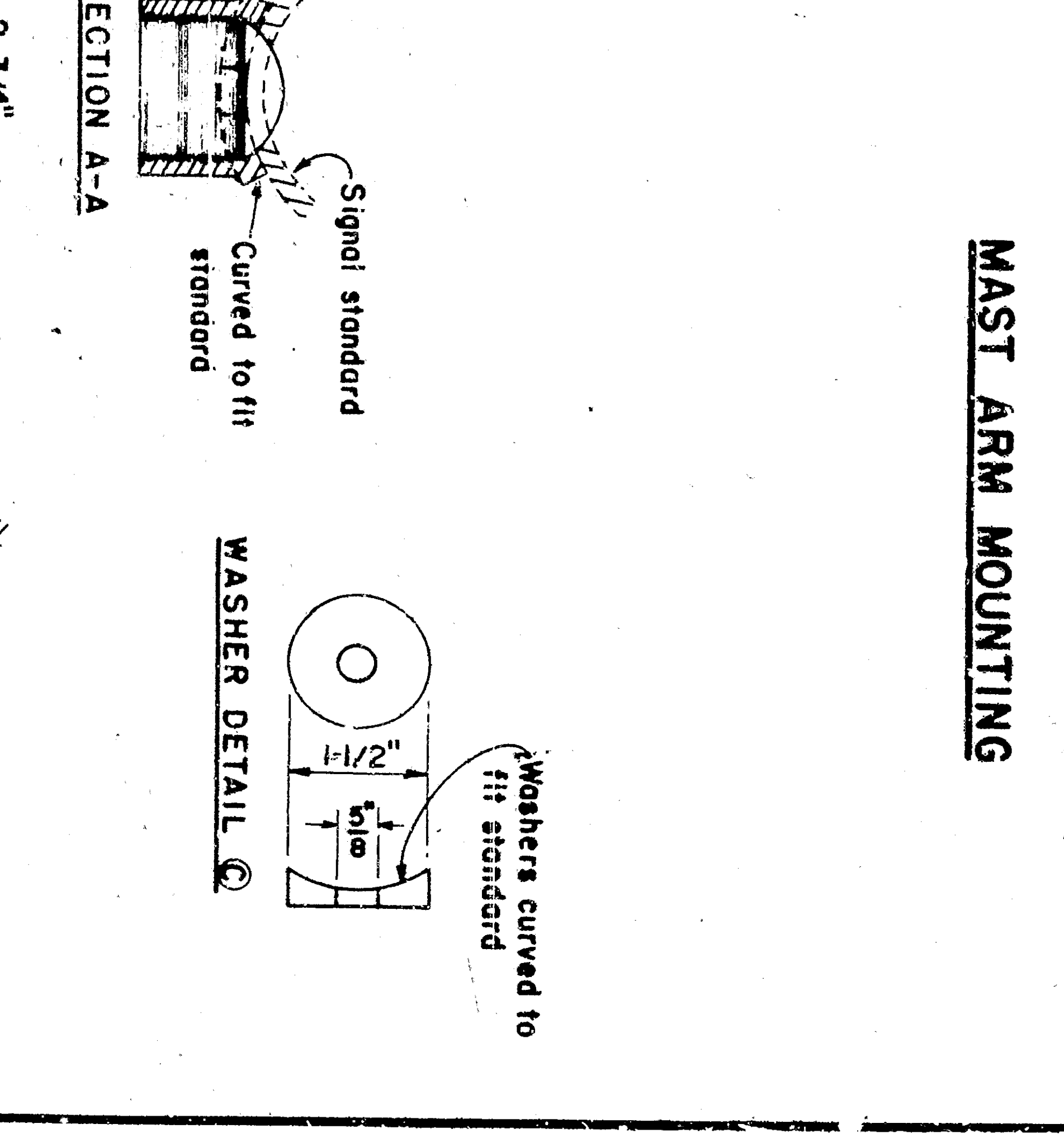
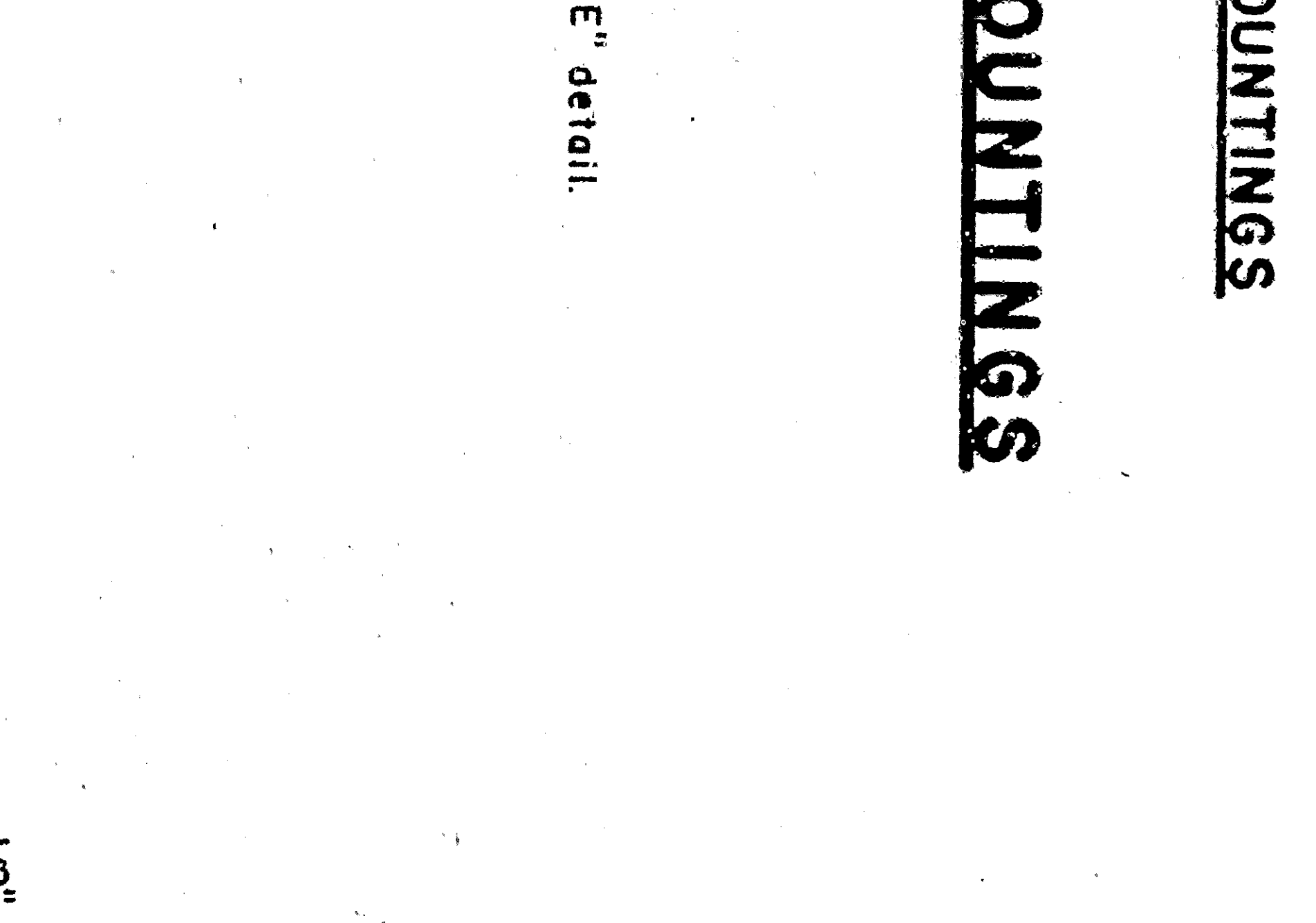
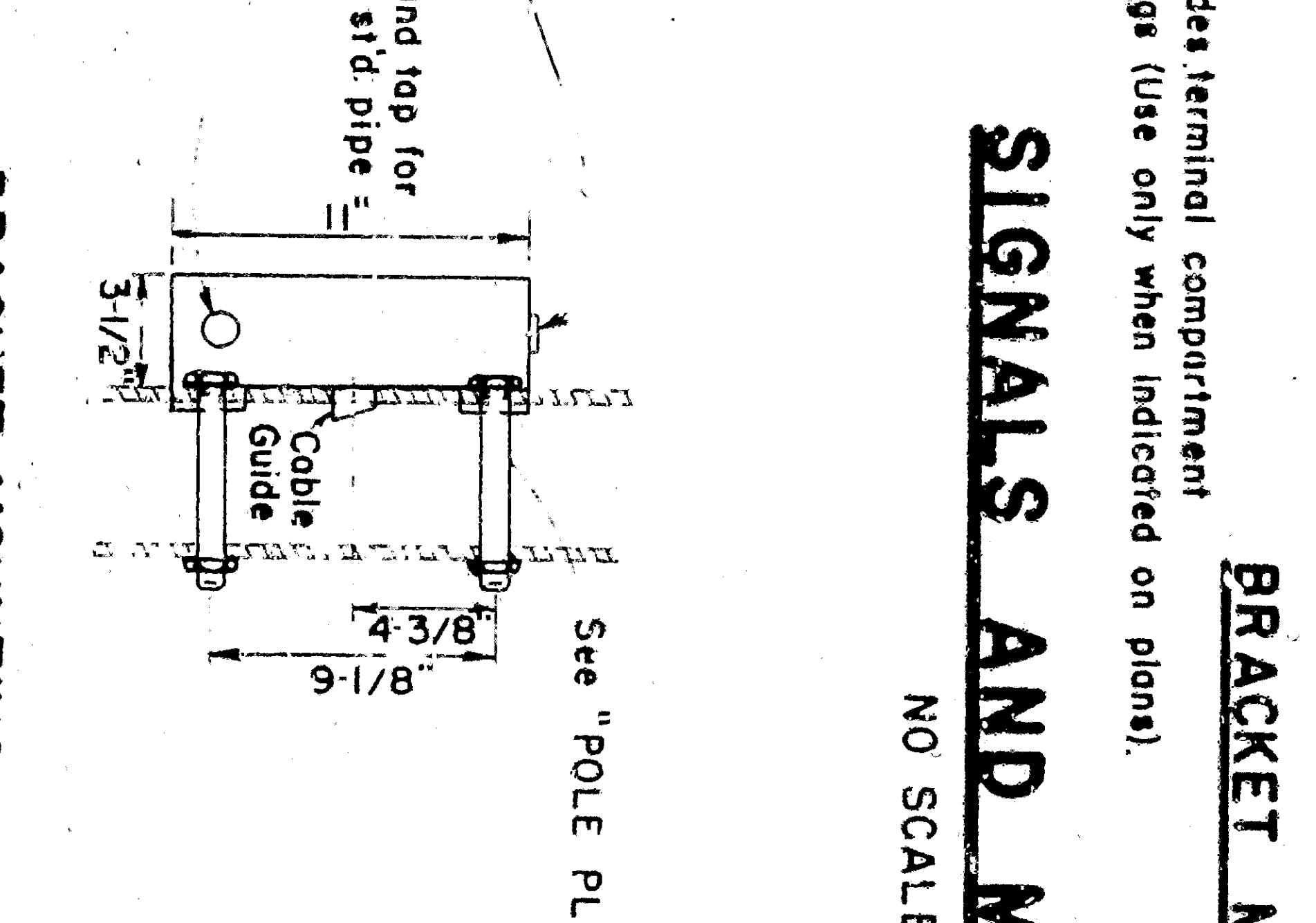
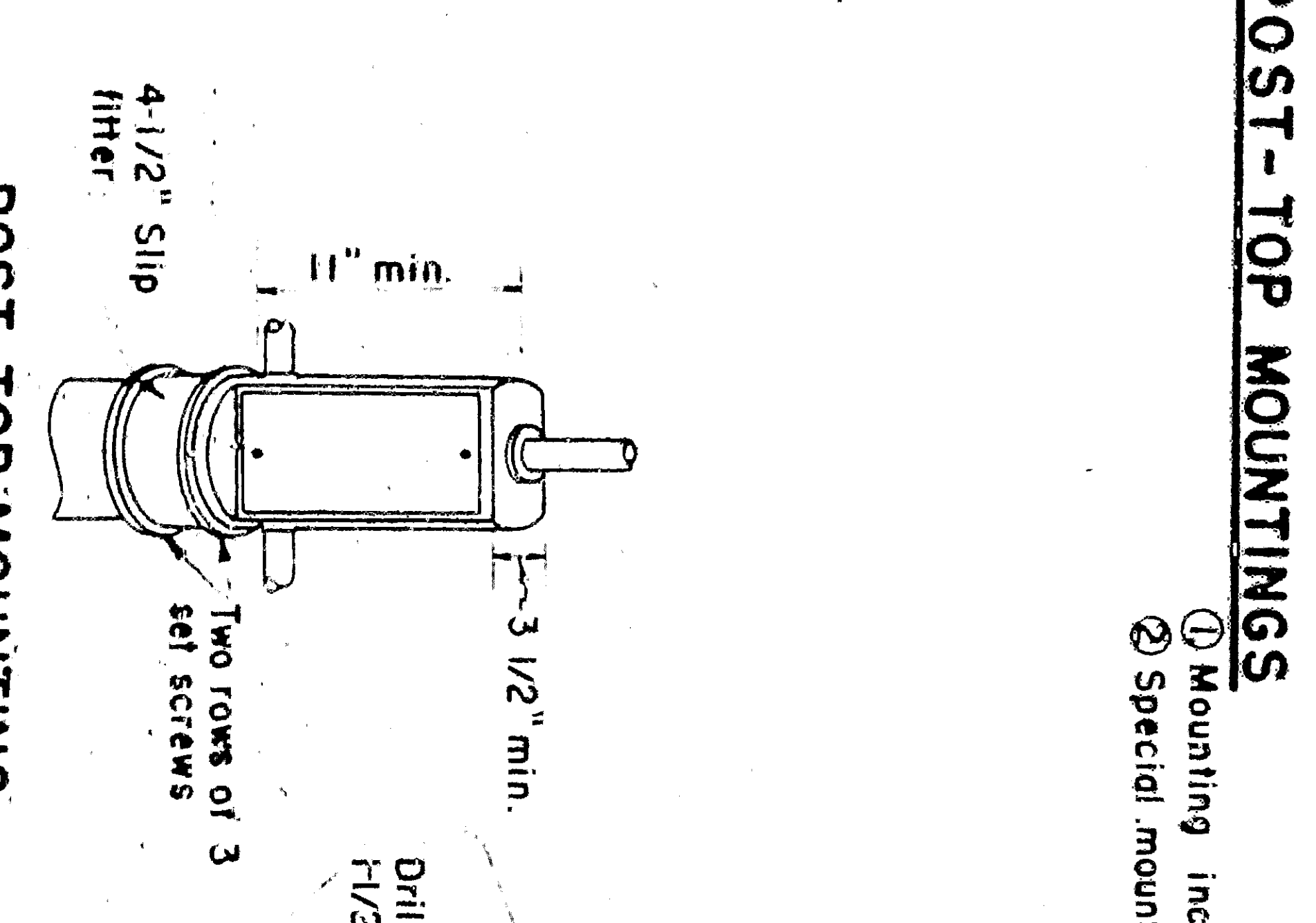
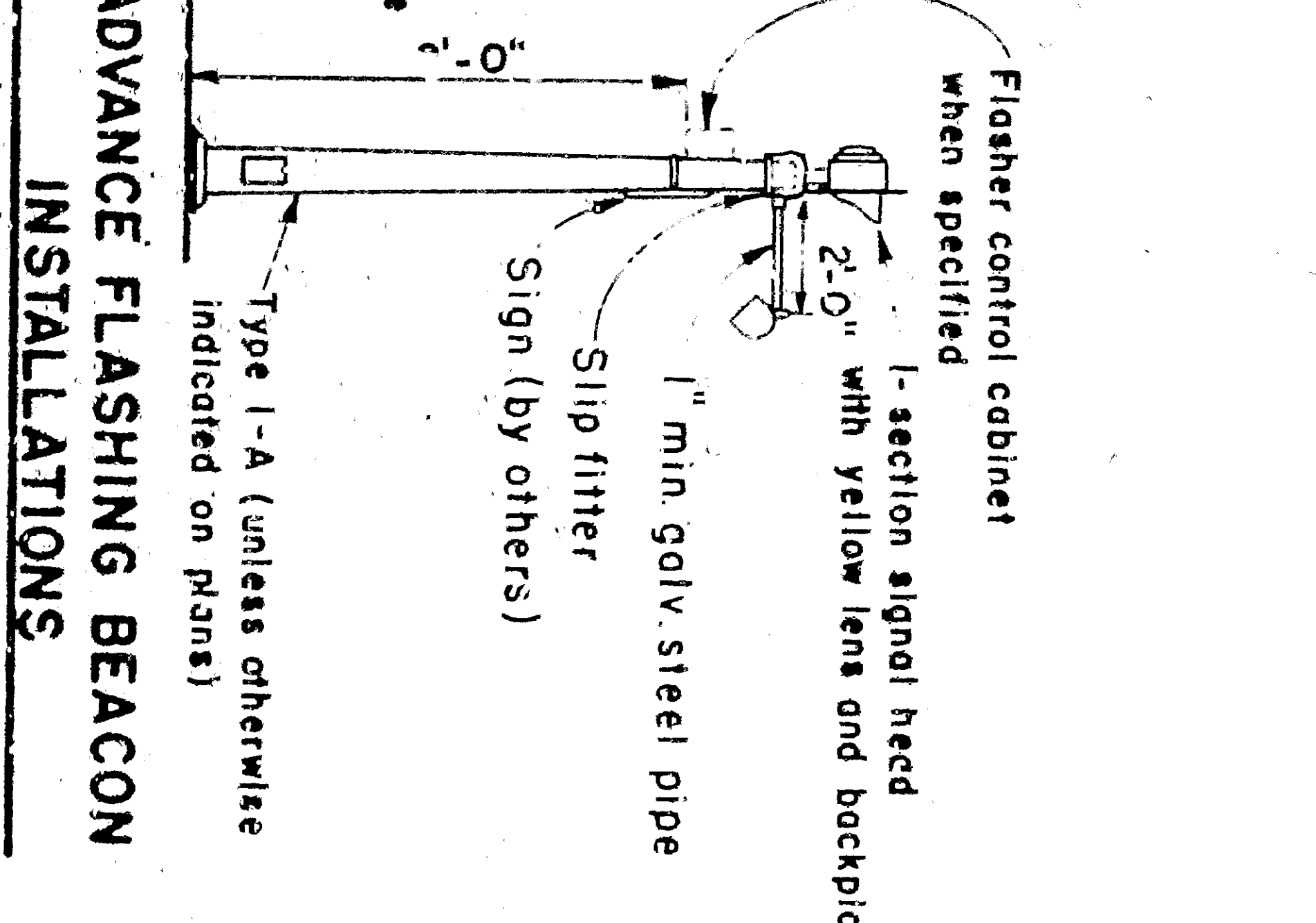
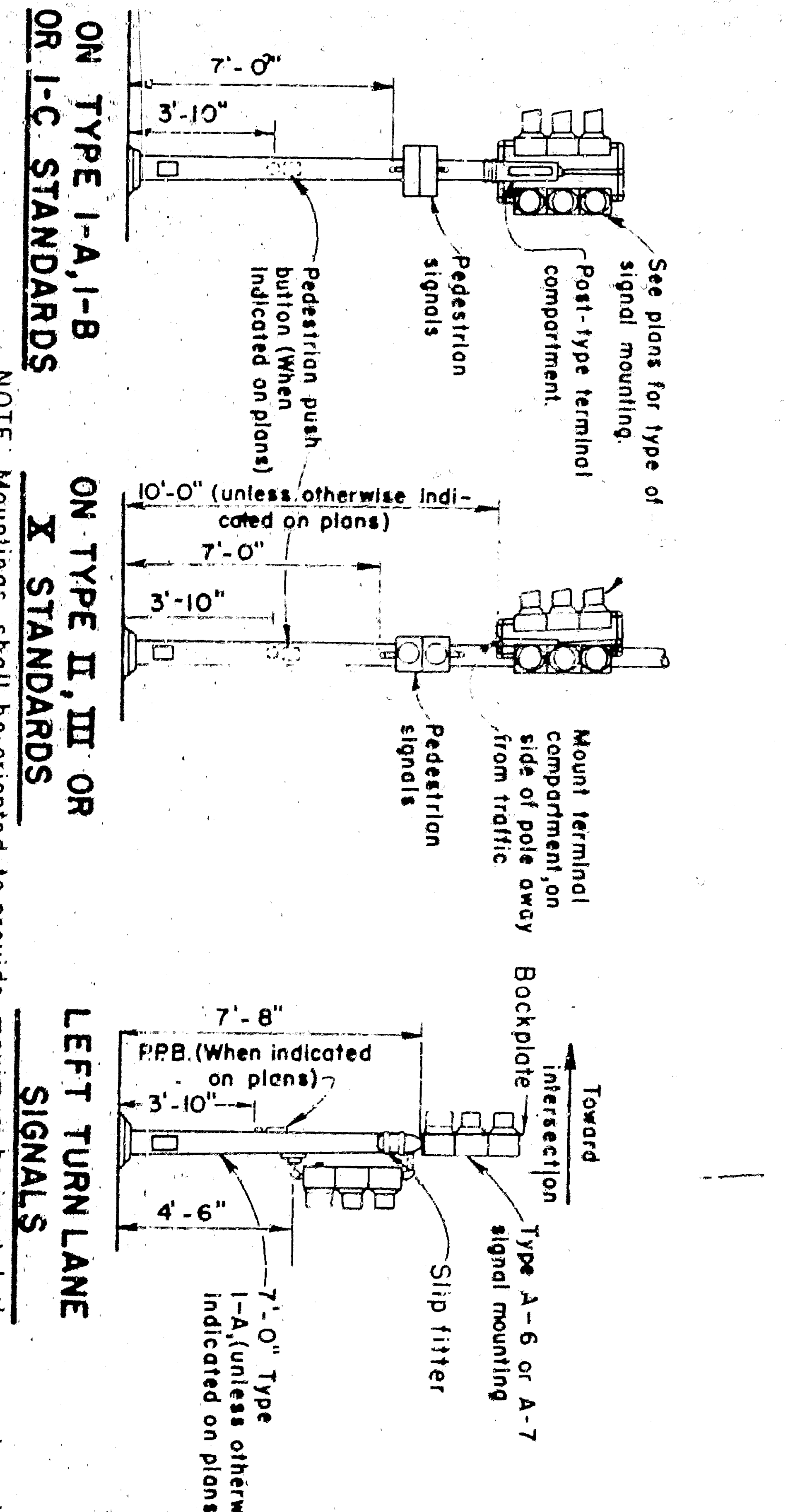
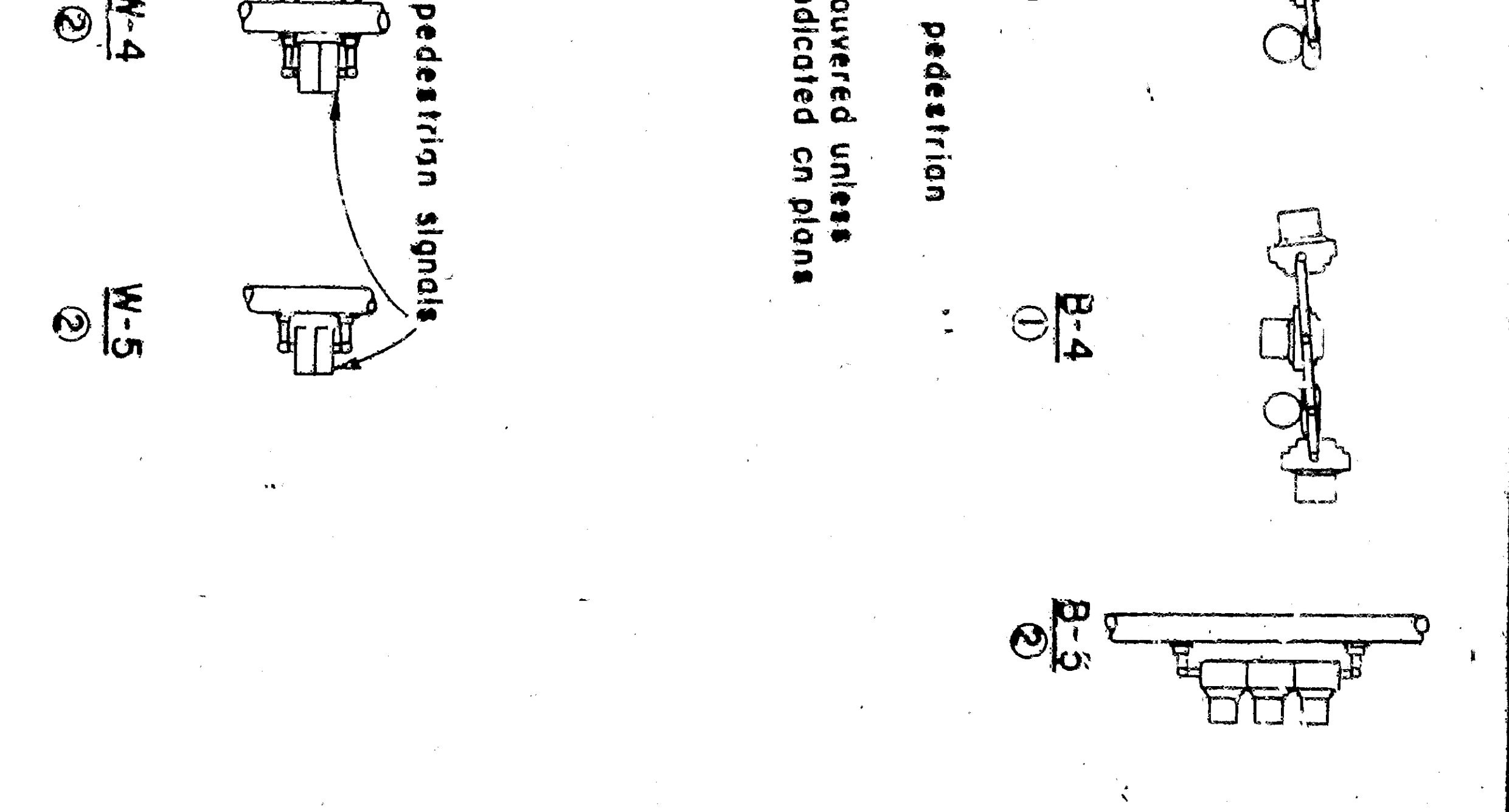
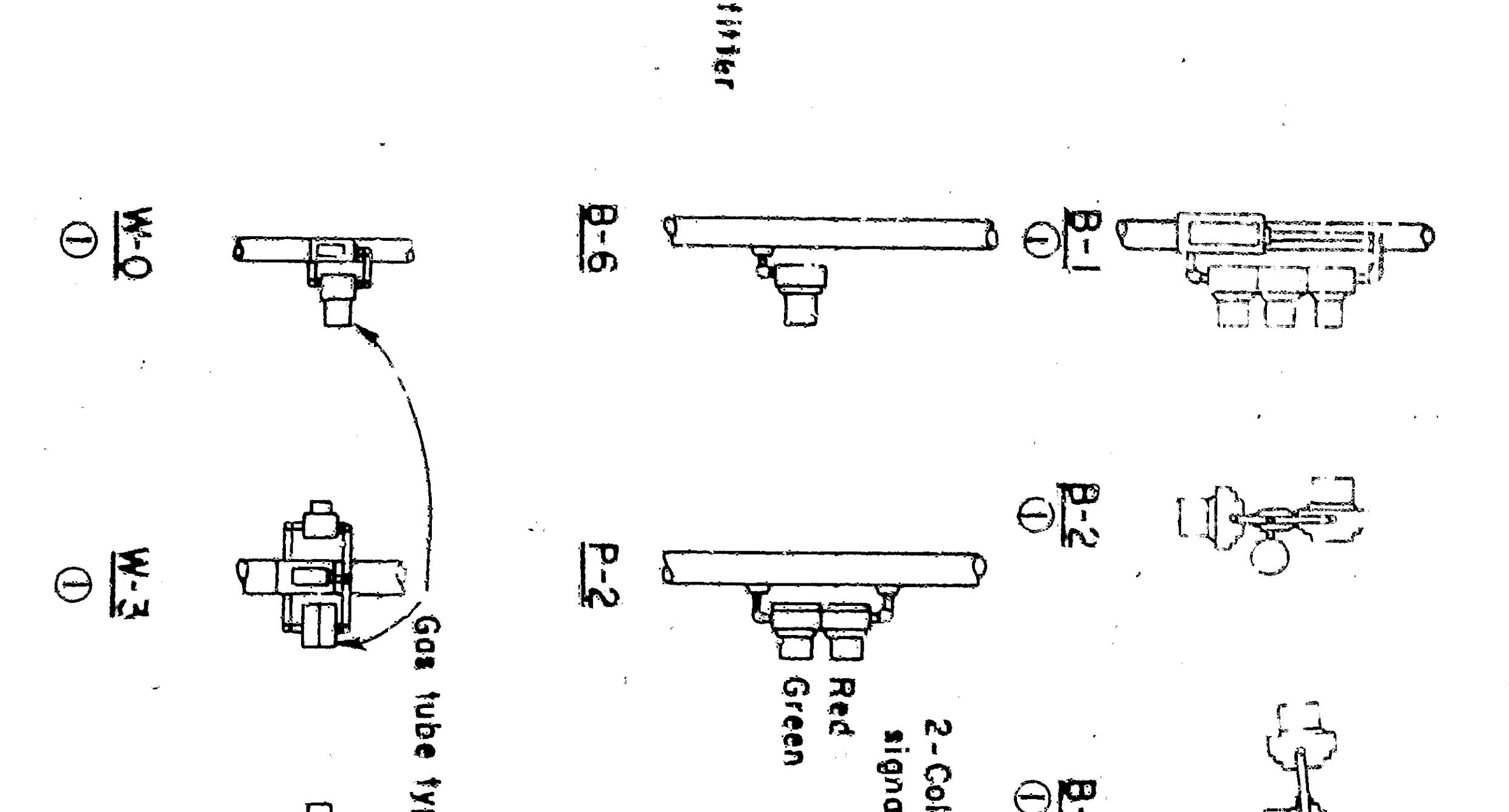
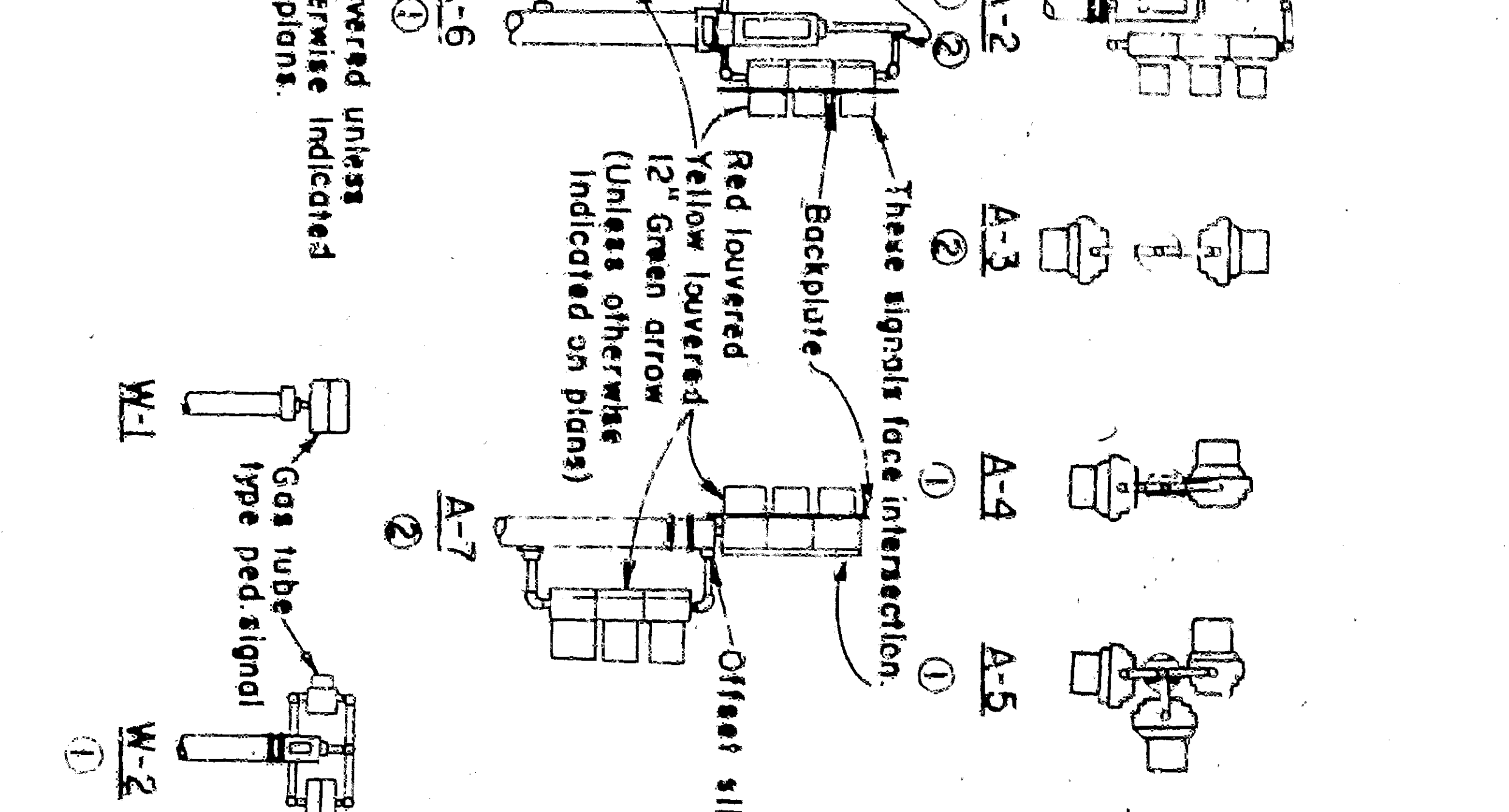
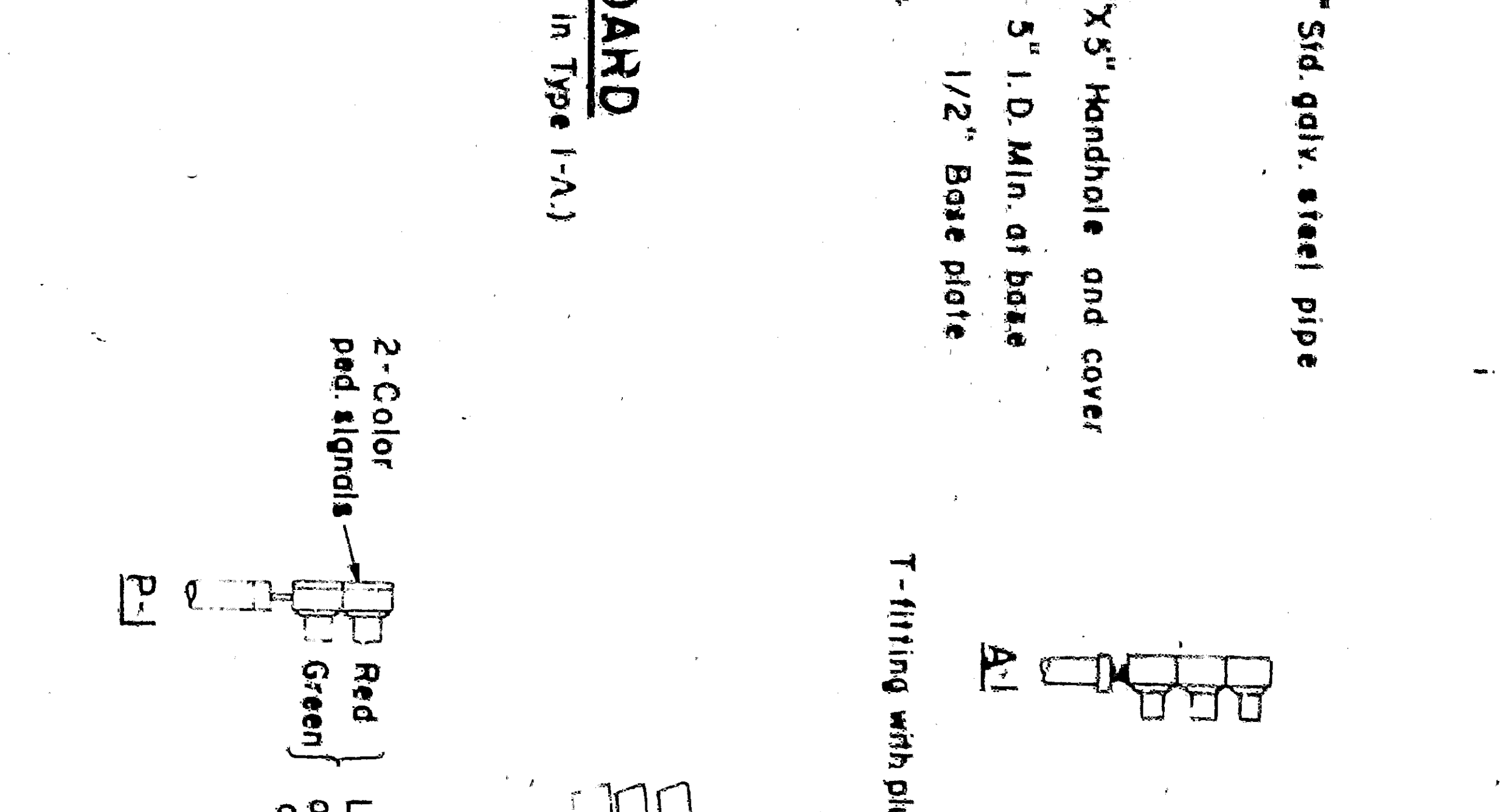
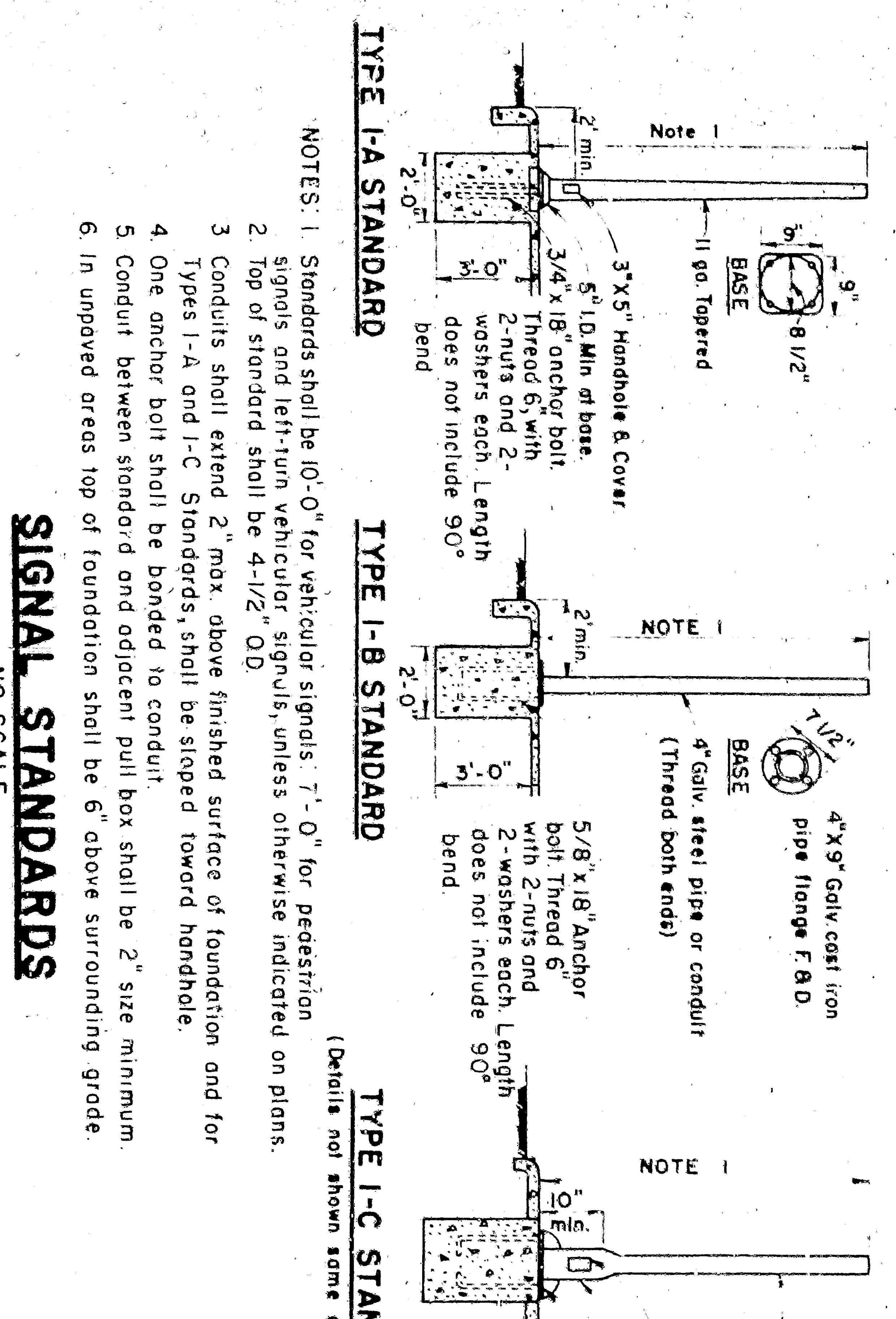